



Specifications	
Precision grade	JIS grade N8 (JIS B1702-1: 1998) * JIS grade 4 (JIS B1702: 1976)
Gear teeth	Standard full depth
Pressure angle	20°
Material	S45C
Heat treatment	Thermal refined *
Tooth hardness	225 ~ 260HB *



\* The precision grade of products with a module less than 0.8 is equivalent to the value shown in the table.  
\* Items with the shape SA are not thermally refined and have a hardness of less than 194HB.

SA

Catalog No.	Module	No. of teeth	Profile shift coefficient	Shape	Shaft dia. (L)		Pitch dia. C	Outside dia. D	Face width E	Shaft dia. (R)		Total length G
					A'	F'				A	F	
SSS0.5-10	m0.5	10	0	SA	—	—	5	6	7	6	38	45
SSS0.5-11		11	0	SA	—	—	5.5	6.5	7	6.5	38	45
SSS0.5-12		12	0	SA	—	—	6	7	7	7	38	45
SSS0.5-13		13	0	SA	—	—	6.5	7.5	7	7.5	38	45
SSS0.8-10	m0.8	10	0	SA	—	—	8	9.6	10	9.6	60	70
SSS0.8-11		11	0	SA	—	—	8.8	10.4	10	10.4	60	70
SSS0.8-12		12	0	SA	—	—	9.6	11.2	10	11.2	60	70
SSS0.8-13		13	0	SA	—	—	10.4	12	10	12	60	70
SSS1-10	m1	10	0	SA	—	—	10	12	12	12	78	90
SSS1-11		11	0	SA	—	—	11	13	12	13	78	90
SSS1-12		12	0	SA	—	—	12	14	12	14	78	90
SSS1-13		13	0	SA	—	—	13	15	12	15	78	90
SSS1.5-10	m1.5	10	+0.5	SB	12.2	25	15	19.35	15	12.2	100	140
SSS1.5-11		11	+0.5	SB	13.7	25	16.5	20.85	15	13.7	100	140
SSS1.5-12		12	0	SB	13.7	25	18	21	15	13.7	100	140
SSS1.5-13		13	0	SB	15.2	25	19.5	22.5	15	15.2	100	140
SSS2-10	m2	10	+0.5	SB	16.2	30	20	25.8	20	16.2	120	170
SSS2-11		11	+0.5	SB	18.2	30	22	27.8	20	18.2	120	170
SSS2-12		12	0	SB	18.2	30	24	28	20	18.2	120	170
SSS2-13		13	0	SB	20.2	30	26	30	20	20.2	120	170
SSS2.5-10	m2.5	10	+0.5	SB	20.2	35	25	32.25	25	20.2	135	195
SSS2.5-11		11	+0.5	SB	22.7	35	27.5	34.75	25	22.7	135	195
SSS2.5-12		12	0	SB	22.7	35	30	35	25	22.7	135	195
SSS2.5-13		13	0	SB	25.2	35	32.5	37.5	25	25.2	135	195
SSS3-10	m3	10	+0.5	SB	24.2	40	30	38.7	30	24.2	150	220
SSS3-11		11	+0.5	SB	27.2	40	33	41.7	30	27.2	150	220
SSS3-12		12	0	SB	27.2	40	36	42	30	27.2	150	220
SSS3-13		13	0	SB	30.2	40	39	45	30	30.2	150	220

[Caution on Product Characteristics]

- The allowable torques shown in the table are calculated values according to the assumed usage conditions. Please see page 35 for more details.
- 10- and 11-tooth gears with a pitch of module 1.5 or greater are profile shifted gears ( $x = +0.5$ ). Please refer to the tables below for calculating the center distance when assembled.
- The backlash values shown in the table are the theoretical values for the normal direction for a pair of identical SS Spur Gears with 30 teeth in mesh.

### Center distance of Stock Spur Gears Meshing with Profile Shifted Spur Gears

The table on the right shows the center distance of the spur gears ( $x=0$ ) which can be meshed with profile shifted spur gears ( $x=+0.5$ ) with module 1. Multiply by the actual module to determine your center distance.

#### Center distance when gear has 12 to 30 teeth (unit : mm)

No. of teeth( $x=0$ )	10	11
12	11.4410	11.9428
13	11.9428	12.4446
14	12.4446	12.9462
15	12.9462	13.4477
16	13.4477	13.9492
17	13.9492	14.4505
18	14.4505	14.9518
19	14.9518	15.4530
20	15.4530	15.9542
21	15.9542	16.4553
22	16.4553	16.9564
23	16.9564	17.4574
24	17.4574	17.9583
25	17.9583	18.4592
26	18.4592	18.9601
27	18.9601	19.4610
28	19.4610	19.9618
29	19.9618	20.4625
30	20.4625	20.9633

#### Center distance when gear has 32 to 62 teeth (unit : mm)

No. of teeth( $x=0$ )	10	11
32	21.4640	21.9647
34	22.4653	22.9660
35	22.9660	23.4666
36	23.4666	23.9671
38	24.4677	24.9683
40	25.4688	25.9693
42	26.4698	26.9703
44	27.4707	27.9712
45	27.9712	28.4716
46	28.4716	28.9721
48	29.4725	29.9729
50	30.4733	30.9736
52	31.4740	31.9744
54	32.4747	32.9750
55	32.9750	33.4754
56	33.4754	33.9757
58	34.4760	34.9763
60	35.4766	35.9769
62	36.4772	36.9774

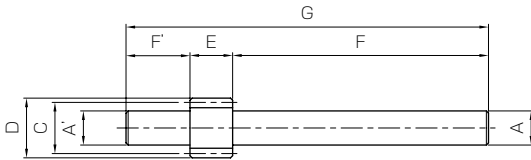

SB

Allowable torque (N-m)		Allowable torque (kgf-m)		Backlash (mm)	Weight (kg)	Catalog No.
Bending strength	Surface durability	Bending strength	Surface durability			
0.20	0.0077	0.021	0.0008	0 ~0.10	0.0095	SSS0.5-10 SSS0.5-11 SSS0.5-12 SSS0.5-13
0.26	0.0094	0.026	0.0010	0 ~0.10	0.011	
0.32	0.011	0.032	0.0011	0 ~0.10	0.013	
0.38	0.013	0.039	0.0014	0 ~0.10	0.015	
0.83	0.032	0.084	0.0032	0 ~0.10	0.038	SSS0.8-10 SSS0.8-11 SSS0.8-12 SSS0.8-13
1.05	0.039	0.11	0.0040	0 ~0.10	0.045	
1.29	0.047	0.13	0.0048	0 ~0.10	0.052	
1.56	0.055	0.16	0.0056	0 ~0.10	0.060	
1.62	0.063	0.16	0.0064	0.09~0.20	0.077	SSS1-10 SSS1-11 SSS1-12 SSS1-13
2.04	0.077	0.21	0.0078	0.09~0.20	0.090	
2.52	0.092	0.26	0.0094	0.09~0.20	0.10	
3.05	0.11	0.31	0.011	0.09~0.20	0.12	
12.7	0.71	1.30	0.073	0.10~0.23	0.14	SSS1.5-10 SSS1.5-11 SSS1.5-12 SSS1.5-13
14.5	0.88	1.48	0.089	0.11~0.24	0.17	
9.97	0.89	1.02	0.091	0.11~0.24	0.17	
12.1	1.05	1.23	0.11	0.11~0.24	0.21	
30.2	1.75	3.08	0.18	0.12~0.26	0.30	SSS2-10 SSS2-11 SSS2-12 SSS2-13
34.3	2.14	3.50	0.22	0.13~0.28	0.38	
23.6	2.18	2.41	0.22	0.13~0.28	0.38	
28.6	2.57	2.92	0.26	0.13~0.28	0.46	
58.9	3.50	6.01	0.36	0.14~0.29	0.54	SSS2.5-10 SSS2.5-11 SSS2.5-12 SSS2.5-13
67.1	4.29	6.84	0.44	0.15~0.31	0.68	
46.2	4.37	4.71	0.45	0.15~0.31	0.68	
55.9	5.13	5.70	0.52	0.15~0.31	0.83	
102	6.15	10.4	0.63	0.15~0.32	0.89	SSS3-10 SSS3-11 SSS3-12 SSS3-13
116	7.54	11.8	0.77	0.16~0.35	1.11	
79.8	7.68	8.14	0.78	0.16~0.35	1.11	
96.5	9.02	9.84	0.92	0.16~0.35	1.35	

- [Caution on Secondary Operations] ① Please read "Caution on Performing Secondary Operations" (Page 36) when performing modifications and/or secondary operations for safety concerns. Haguruma Kobo, the KHK's system for quick modification of KHK stock gears is also available.  
 ② Avoid performing secondary operations that narrow the tooth width as it affects precision and strength.

Center distance when gear has 64 to 200 teeth (unit : mm)

No. of teeth(=0)	No. of teeth(=+0.5)	10	11
64		37.4777	37.9780
65		37.9780	38.4782
66		38.4782	38.9785
68		39.4787	39.9790
70		40.4792	40.9794
72		41.4796	41.9799
75		42.9803	43.4805
76		43.4805	43.9807
80		45.4813	45.9814
84		47.4820	47.9822
85		47.9822	48.4823
88		49.4826	49.9828
90		50.4830	50.9831
95		52.9837	53.4838
100		55.4844	55.9845
120		65.4866	65.9867
150		80.4890	80.9890
200		105.4915	105.9915

Assembly distance of profile shifted gear and the meshing rack

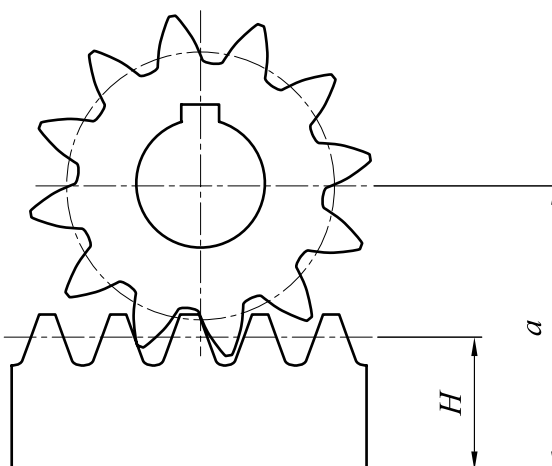

$$a = \frac{zm}{2} + H + xm$$

- Where  
 $a$  : Assembly Distance  
 $H$  : Height of pitch line of rack  
 $m$  : Module  
 $z$  : No. of Teeth  
 $x$  : Profile Shift Coefficient