



Spur Gears

Helical Gears

Internal Gears

Racks

CP Racks & Pinions

Miter Gears

Bevel Gears

Screw Gears

Worm Gear Pair

Bevel Gearboxes

Other Products



Specifications	
Precision grade	JIS grade N8 (JIS B1702-1: 1998) * JIS grade 4 (JIS B1702: 1976)
Gear teeth	Standard full depth
Pressure angle	20°
Material	SUS303
Heat treatment	—
Tooth hardness	less than 187HB

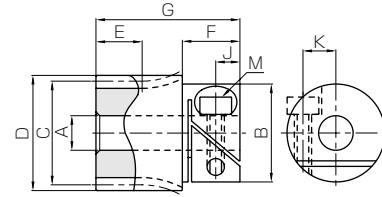

* The gear grade listed is the value before clamping. The precision grade of products with a module of less than 0.8 is equivalent to the value shown in the table.

S3

Catalog No.	Module	No. of teeth	Shape	Bore							Cap screw dimensions		
				A _{H7}	B	C	D	E	F	G	M	J	K
SUSL0.5-16	m0.5	16	S3	4	14	8	9	7	8	22	M2.5	3.3	4.4
SUSL0.5-18		18	S3	4	14	9	10	7	8	22	M2.5	3.3	4.4
SUSL0.5-20		20	S3	4	14	10	11	7	8	22	M2.5	3.3	4.4
SUSL0.5-24		24	S3	5	14	12	13	7	8	22	M2.5	3.3	4.4
SUSL0.5-25		25	S3	5	14	12.5	13.5	7	8	22	M2.5	3.3	4.4
SUSL0.5-28		28	S3	5	14	14	15	7	8	22	M2.5	3.3	4.4
SUSL0.5-30		30	S3	5	14	15	16	7	8	22	M2.5	3.3	4.4
SUSL0.5-32		32	S3	6	17	16	17	5	10	15	M3	4.5	5.3
SUSL0.5-36		36	S3	6	17	18	19	5	10	15	M3	4.5	5.3
SUSL0.5-40		40	S1	6	17	20	21	5	10	15	M3	4.5	5.3
SUSL0.5-45		45	S1	6	17	22.5	23.5	5	10	15	M3	4.5	5.3
SUSL0.5-48		48	S1	6	17	24	25	5	10	15	M3	4.5	5.3
SUSL0.5-50		50	S1	6	17	25	26	5	10	15	M3	4.5	5.3
SUSL0.5-54		54	S1	6	17	27	28	5	10	15	M3	4.5	5.3
SUSL0.5-56		56	S1	6	17	28	29	5	10	15	M3	4.5	5.3
SUSL0.5-60		60	S1	8	17	30	31	5	10	15	M3	4.5	6
SUSL0.5-64		64	S1	8	17	32	33	5	10	15	M3	4.5	6
SUSL0.5-70		70	S1	8	17	35	36	5	10	15	M3	4.5	6
SUSL0.5-72		72	S1	8	17	36	37	5	10	15	M3	4.5	6
SUSL0.5-75		75	S1	8	17	37.5	38.5	5	10	15	M3	4.5	6
SUSL0.5-80	80	S1	10	24	40	41	5	14	19	M4	5.3	7.7	
SUSL0.5-90	90	S1	10	24	45	46	5	14	19	M4	5.3	7.7	
SUSL0.5-96	96	S1	10	24	48	49	5	14	19	M4	4.9	8	
SUSL0.5-100	100	S1	10	24	50	51	5	14	19	M4	4.9	8	
SUSL0.5-112	112	S1	10	24	56	57	5	14	19	M4	4.9	8	
SUSL0.5-120	120	S1	10	24	60	61	5	14	19	M4	4.9	8	
SUSL0.8-14	m0.8	14	S3	4	14	11.2	12.8	7	8	22	M2.5	3.3	4.4
SUSL0.8-15		15	S3	4	14	12	13.6	7	8	22	M2.5	3.3	4.4
SUSL0.8-16		16	S3	4	14	12.8	14.4	7	8	22	M2.5	3.3	4.4
SUSL0.8-18		18	S3	4	14	14.4	16	7	8	22	M2.5	3.3	4.4
SUSL0.8-20		20	S1	4	14	16	17.6	5	8	13	M2.5	3.3	4.4
SUSL0.8-22		22	S1	4	14	17.6	19.2	5	8	13	M2.5	3.3	4.4
SUSL0.8-24		24	S1	5	14	19.2	20.8	5	8	13	M2.5	3.3	4.4
SUSL0.8-25		25	S1	5	14	20	21.6	5	8	13	M2.5	3.3	4.4
SUSL0.8-28		28	S1	5	14	22.4	24	5	8	13	M2.5	3.3	4.4
SUSL0.8-30		30	S1	5	14	24	25.6	5	8	13	M2.5	3.3	4.4

[Caution on Product Characteristics]

- ① The allowable torques shown in the table are calculated values according to the assumed usage conditions. Please see page 35 for more details.
- ② The backlash values shown in the table are the theoretical values for the backlash in the normal direction of a pair of identical gears in mesh.
- ③ Fairloc Hub Gears are attached to the shaft by friction. Slipping torque should be considered when making a selection.
- ④ Do not tighten the clamping screw without inserting a shaft, or the bore will be permanently deformed and will not accept a shaft
- ⑤ The hub configurations are slightly different from the drawings shown above. But there is no difference in functionality.

Fastening torque vs. Slipping torque

The slipping torque which is dependent on the fastening torque can sometimes be less than the gear strength. Please use caution in selecting. The chart on the right shows the relationship between the slipping torque and the fastening torque.

Fastening torque vs. Slipping torque

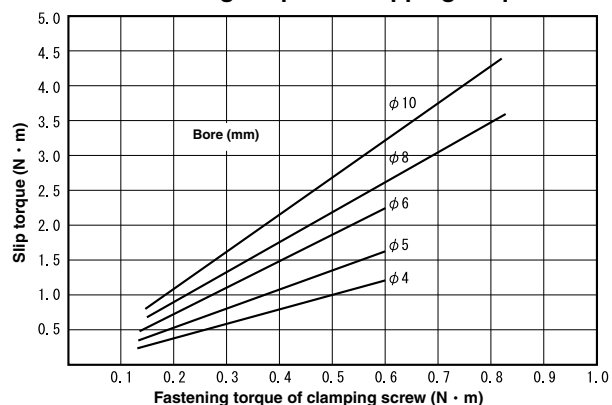

※ Data supplied by Designtronics Inc.

Stainless Steel Fairloc Hub Spur Gears

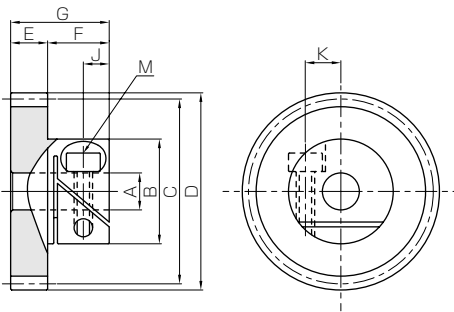

S1

Allowable torque (N-m)		Allowable torque (kgf-m)		Recommended fastening torque		Backlash (mm)	Weight (kg)	Catalog No.
Bending strength	Surface durability	Bending strength	Surface durability	(N-m)	(kgf-m)			
0.40	0.023	0.04	0.0023	0.60	0.061	0~0.10	0.012	SUSL0.5-16
0.47	0.03	0.048	0.0031	0.60	0.061	0~0.10	0.013	SUSL0.5-18
0.56	0.038	0.057	0.0039	0.60	0.061	0~0.10	0.015	SUSL0.5-20
0.72	0.056	0.074	0.0057	0.60	0.061	0~0.10	0.018	SUSL0.5-24
0.76	0.061	0.078	0.0062	0.60	0.061	0~0.10	0.019	SUSL0.5-25
0.89	0.079	0.091	0.0080	0.60	0.061	0~0.10	0.022	SUSL0.5-28
0.98	0.091	0.10	0.0093	0.60	0.061	0~0.10	0.025	SUSL0.5-30
0.76	0.076	0.078	0.0077	0.60	0.061	0~0.10	0.021	SUSL0.5-32
0.89	0.096	0.091	0.0098	0.60	0.061	0~0.10	0.023	SUSL0.5-36
1.02	0.12	0.10	0.012	0.60	0.061	0~0.10	0.025	SUSL0.5-40
1.18	0.15	0.12	0.016	0.60	0.061	0~0.10	0.029	SUSL0.5-45
1.28	0.17	0.13	0.018	0.60	0.061	0~0.10	0.031	SUSL0.5-48
1.34	0.19	0.14	0.019	0.60	0.061	0~0.10	0.032	SUSL0.5-50
1.48	0.22	0.15	0.023	0.60	0.061	0~0.10	0.035	SUSL0.5-54
1.54	0.24	0.16	0.025	0.60	0.061	0~0.10	0.037	SUSL0.5-56
1.67	0.28	0.17	0.029	0.80	0.082	0~0.10	0.038	SUSL0.5-60
1.81	0.32	0.18	0.033	0.80	0.082	0~0.10	0.042	SUSL0.5-64
2.01	0.39	0.20	0.04	0.80	0.082	0~0.10	0.048	SUSL0.5-70
2.07	0.41	0.21	0.042	0.80	0.082	0~0.10	0.050	SUSL0.5-72
2.17	0.45	0.22	0.046	0.80	0.082	0~0.10	0.054	SUSL0.5-75
2.34	0.51	0.24	0.053	0.80	0.082	0~0.10	0.084	SUSL0.5-80
2.68	0.66	0.27	0.067	0.80	0.082	0~0.10	0.097	SUSL0.5-90
2.88	0.76	0.29	0.077	0.80	0.082	0~0.10	0.11	SUSL0.5-96
3.02	0.82	0.31	0.084	0.80	0.082	0~0.10	0.11	SUSL0.5-100
3.42	1.05	0.35	0.11	0.80	0.082	0~0.10	0.13	SUSL0.5-112
3.69	1.21	0.38	0.12	0.80	0.082	0~0.10	0.15	SUSL0.5-120
0.82	0.048	0.083	0.0049	0.60	0.061	0~0.10	0.017	SUSL0.8-14
0.92	0.056	0.093	0.0057	0.60	0.061	0~0.10	0.019	SUSL0.8-15
1.01	0.065	0.10	0.0066	0.60	0.061	0~0.10	0.021	SUSL0.8-16
1.22	0.083	0.12	0.0085	0.60	0.061	0~0.10	0.024	SUSL0.8-18
1.02	0.076	0.10	0.0077	0.60	0.061	0~0.10	0.015	SUSL0.8-20
1.17	0.091	0.12	0.0093	0.60	0.061	0~0.10	0.017	SUSL0.8-22
1.32	0.11	0.13	0.011	0.60	0.061	0~0.10	0.018	SUSL0.8-24
1.40	0.12	0.14	0.012	0.60	0.061	0~0.10	0.019	SUSL0.8-25
1.63	0.15	0.17	0.015	0.60	0.061	0~0.10	0.022	SUSL0.8-28
1.79	0.17	0.18	0.018	0.60	0.061	0~0.10	0.024	SUSL0.8-30

[Caution on Secondary Operations]

- ① These are finished products, avoid performing secondary operations on the bore.
- ② Perform secondary operations carefully as to not distort the groove for clamping.

Spur Gears

Helical Gears

Internal Gears

Racks

CP Racks & Pinions

Miter Gears

Bevel Gears

Screw Gears

Worm Gear Pair

Bevel Gearboxes

Other Products



Specifications	
Precision grade	JIS grade N8 (JIS B1702-1: 1998) * JIS grade 4 (JIS B1702: 1976)
Gear teeth	Standard full depth
Pressure angle	20°
Material	SUS303
Heat treatment	—
Tooth hardness	less than 187HB

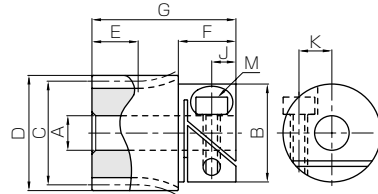

* The gear grade listed is the value before clamping. The precision grade of products with a module of less than 0.8 is equivalent to the value shown in the table.

S3

Catalog No.	Module	No. of teeth	Shape	Bore	Hub dia.	Pitch dia.	Outside dia.	Face width	Hub width	Total length	Cap screw dimensions		
				AH7	B	C	D	E	F	G	M	J	K
SUSL0.8-32	m0.8	32	S1	5	14	25.6	27.2	5	8	13	M2.5	3.3	4.4
SUSL0.8-36		36	S1	6	17	28.8	30.4	5	10	15	M3	4.5	5.3
SUSL0.8-40		40	S1	6	17	32	33.6	5	10	15	M3	4.5	5.3
SUSL0.8-45		45	S1	6	17	36	37.6	5	10	15	M3	4.5	5.3
SUSL0.8-48		48	S1	6	17	38.4	40	5	10	15	M3	4.5	5.3
SUSL0.8-50		50	S1	6	17	40	41.6	5	10	15	M3	4.5	5.3
SUSL0.8-54		54	S1	6	17	43.2	44.8	5	10	15	M3	4.5	5.3
SUSL0.8-56		56	S1	6	17	44.8	46.4	5	10	15	M3	4.5	5.3
SUSL0.8-60		60	S1	8	17	48	49.6	5	10	15	M3	4.5	6
SUSL0.8-64		64	S1	8	17	51.2	52.8	5	10	15	M3	4.5	6
SUSL0.8-72	m1	72	S1	8	17	57.6	59.2	5	10	15	M3	4.5	6
SUSL0.8-80		80	S1	10	24	64	65.6	5	14	19	M4	4.9	8
SUSL0.8-90		90	S1	10	24	72	73.6	5	14	19	M4	4.9	8
SUSL0.8-100		100	S1	10	24	80	81.6	5	14	19	M4	4.9	8
SUSL1-14	m1	14	S3	6	17	14	16	8	10	25	M3	4.5	5.3
SUSL1-15		15	S3	6	17	15	17	8	10	25	M3	4.5	5.3
SUSL1-16		16	S3	6	17	16	18	8	10	25	M3	4.5	5.3
SUSL1-18		18	S3	6	17	18	20	8	10	25	M3	4.5	5.3
SUSL1-20		20	S1	6	17	20	22	6	10	16	M3	4.5	5.3
SUSL1-24		24	S1	6	17	24	26	6	10	16	M3	4.5	5.3
SUSL1-25		25	S1	6	17	25	27	6	10	16	M3	4.5	5.3
SUSL1-28		28	S1	6	17	28	30	6	10	16	M3	4.5	5.3
SUSL1-30		30	S1	8	17	30	32	6	10	16	M3	4.5	6
SUSL1-32		32	S1	8	17	32	34	6	10	16	M3	4.5	6
SUSL1-35		35	S1	8	17	35	37	6	10	16	M3	4.5	6
SUSL1-36		36	S1	8	17	36	38	6	10	16	M3	4.5	6
SUSL1-40		40	S1	8	17	40	42	6	10	16	M3	4.5	6
SUSL1-45		45	S1	8	17	45	47	6	10	16	M3	4.5	6
SUSL1-48		48	S1	8	17	48	50	6	10	16	M3	4.5	6
SUSL1-50		50	S1	10	24	50	52	6	14	20	M4	4.9	8
SUSL1-56		56	S1	10	24	56	58	6	14	20	M4	4.9	8
SUSL1-60		60	S1	10	24	60	62	6	14	20	M4	4.9	8
SUSL1-64		64	S1	10	24	64	66	6	14	20	M4	4.9	8
SUSL1-70		70	S1	10	24	70	72	6	14	20	M4	4.9	8
SUSL1-72	72	S1	10	24	72	74	6	14	20	M4	4.9	8	
SUSL1-80	80	S1	10	24	80	82	6	14	20	M4	4.9	8	
SUSL1-90	90	S1	10	24	90	92	6	14	20	M4	4.9	8	
SUSL1-100	100	S1	10	24	100	102	6	14	20	M4	4.9	8	

[Caution on Product Characteristics]

- ① The allowable torques shown in the table are calculated values according to the assumed usage conditions. Please see page 35 for more details.
- ② The backlash values shown in the table are the theoretical values for the backlash in the normal direction of a pair of identical gears in mesh.
- ③ Fairloc Hub Gears are attached to the shaft by friction. Slipping torque should be considered when making a selection.
- ④ Do not tighten the clamping screw without inserting a shaft, or the bore will be permanently deformed and will not accept a shaft
- ⑤ The hub configurations are slightly different from the drawings shown above. But there is no difference in functionality.

Fastening torque vs. Slipping torque

The slipping torque which is dependent on the fastening torque can sometimes be less than the gear strength. Please use caution in selecting. The chart on the right shows the relationship between the slipping torque and the fastening torque.

Fastening torque vs. Slipping torque

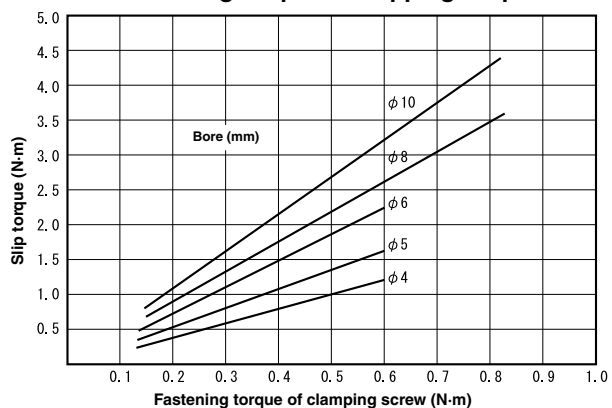

※ Data supplied by Designatronics Inc.

Stainless Steel Fairloc Hub Spur Gears

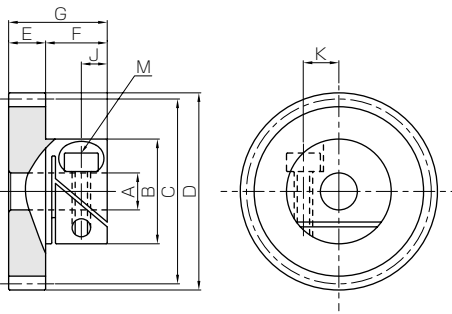

S1

Allowable torque (N-m)		Allowable torque (kgf-m)		Recommended fastening torque		Backlash (mm)	Weight (kg)	Catalog No.
Bending strength	Surface durability	Bending strength	Surface durability	(N-m)	(kgf-m)			
1.95	0.20	0.20	0.020	0.60	0.061	0~0.10	0.027	SUSL0.8-32
2.28	0.26	0.23	0.026	0.60	0.061	0~0.10	0.038	SUSL0.8-36
2.61	0.32	0.27	0.033	0.60	0.061	0~0.10	0.044	SUSL0.8-40
3.02	0.41	0.31	0.042	0.60	0.061	0~0.10	0.053	SUSL0.8-45
3.27	0.47	0.33	0.048	0.60	0.061	0~0.10	0.058	SUSL0.8-48
3.44	0.51	0.35	0.053	0.60	0.061	0~0.10	0.062	SUSL0.8-50
3.78	0.61	0.39	0.062	0.60	0.061	0~0.10	0.070	SUSL0.8-54
3.95	0.65	0.40	0.067	0.60	0.061	0~0.10	0.075	SUSL0.8-56
4.28	0.76	0.44	0.077	0.80	0.082	0~0.10	0.081	SUSL0.8-60
4.63	0.87	0.47	0.088	0.80	0.082	0~0.10	0.091	SUSL0.8-64
5.31	1.11	0.54	0.11	0.80	0.082	0~0.10	0.11	SUSL0.8-72
6.00	1.38	0.61	0.14	0.80	0.082	0~0.10	0.16	SUSL0.8-80
6.86	1.77	0.70	0.18	0.80	0.082	0~0.10	0.19	SUSL0.8-90
7.72	2.21	0.79	0.23	0.80	0.082	0~0.10	0.23	SUSL0.8-100
1.46	0.088	0.15	0.0090	0.60	0.061	0~0.10	0.029	SUSL1-14
1.63	0.10	0.17	0.010	0.60	0.061	0~0.10	0.032	SUSL1-15
1.81	0.12	0.18	0.012	0.60	0.061	0~0.10	0.034	SUSL1-16
2.17	0.15	0.22	0.016	0.60	0.061	0~0.10	0.041	SUSL1-18
1.91	0.14	0.19	0.015	0.60	0.061	0~0.10	0.028	SUSL1-20
2.48	0.21	0.25	0.021	0.60	0.061	0~0.10	0.034	SUSL1-24
2.62	0.23	0.27	0.023	0.60	0.061	0~0.10	0.036	SUSL1-25
3.06	0.29	0.31	0.030	0.60	0.061	0~0.10	0.042	SUSL1-28
3.36	0.34	0.34	0.034	0.80	0.082	0~0.10	0.043	SUSL1-30
3.66	0.39	0.37	0.039	0.80	0.082	0~0.10	0.048	SUSL1-32
4.12	0.47	0.42	0.048	0.80	0.082	0~0.10	0.055	SUSL1-35
4.27	0.49	0.44	0.050	0.80	0.082	0~0.10	0.058	SUSL1-36
4.89	0.62	0.50	0.063	0.80	0.082	0~0.10	0.069	SUSL1-40
5.67	0.79	0.58	0.081	0.80	0.082	0~0.10	0.085	SUSL1-45
6.14	0.91	0.63	0.093	0.80	0.082	0~0.10	0.095	SUSL1-48
6.45	0.99	0.66	0.10	0.80	0.082	0~0.10	0.13	SUSL1-50
7.40	1.25	0.75	0.13	0.80	0.082	0~0.10	0.15	SUSL1-56
8.03	1.45	0.82	0.15	0.80	0.082	0~0.10	0.17	SUSL1-60
8.67	1.66	0.88	0.17	0.80	0.082	0~0.10	0.19	SUSL1-64
9.63	2.00	0.98	0.20	0.80	0.082	0~0.10	0.21	SUSL1-70
9.95	2.12	1.02	0.22	0.80	0.082	0~0.10	0.23	SUSL1-72
11.2	2.65	1.15	0.27	0.80	0.082	0~0.10	0.27	SUSL1-80
12.9	3.40	1.31	0.35	0.80	0.082	0~0.10	0.33	SUSL1-90
14.5	4.25	1.48	0.43	0.80	0.082	0~0.10	0.40	SUSL1-100

[Caution on Secondary Operations]

- ① These are finished products, avoid performing secondary operations on the bore.
 ② Perform secondary operations carefully as to not distort the groove for clamping.

Spur
GearsHelical
GearsInternal
Gears

Racks

CP Racks
& PinionsMiter
GearsBevel
GearsScrew
GearsWorm
Gear PairBevel
GearboxesOther
Products